

**Serie | 6, Ceiling cooker hood, 90 cm,  
Stainless steel  
DRC97AQ50B**

A



**Optional accessories**

DIZ0JC2D0 : Long Life recirc. kit external white  
 DIZ0JC5D0 : Long Life recirc. kit external inox  
 DIZ1JC2C6 : Clean Air Plus recirc.kit external white  
 DIZ1JC5C6 : Clean Air Plus recirc. kit external inox  
 DZZ1XX1B6 : Clean Air Plus odor filter (replacement)

**The integrated ceiling hood: the powerful and effective solution for larger and open plan kitchens, perfectly installed directly into the ceiling.**

- **Especially silent:** maximum hood performance, minimum noise.
- **Easy-to-clean interior:** hidden screws and cables along with rounded edges make cleaning easy.
- Manage your appliances with your voice, thanks to the Amazon Alexa voice control.\*
- **Cooktop-based hood control:** use the hob to control your hood.
- **Home Connect:** hoods with smart connectivity make life easier.

**Technical Data**

Typology : Island/Ceiling  
 Approval certificates : CE, E17D UKCA marking, VDE  
 Length of electrical supply cord : 130 cm  
 Required niche size for installation (HxWxD) : 299mm x 888.0mm x 487mm mm  
 Minimum distance above an electric hob : 650 mm  
 Minimum distance above a gas hob : 650 mm  
 Net weight : 24.304 kg  
 Type of control : Electronic  
 Number of speed settings : 3-stage + 2 intensive  
 Maximum output air extraction : 459 m<sup>3</sup>/h  
 Boost position output recirculating : 565.0 m<sup>3</sup>/h  
 Maximum output recirculating air : 422 m<sup>3</sup>/h  
 Boost position air extraction : 798 m<sup>3</sup>/h  
 Number of lights (Stck) : 4  
 Noise level : 56 dB(A) re 1 pW  
 Diameter of air outlet : 150 mm  
 Grease filter material : Washable stainless steel  
 EAN code : 4242005103997  
 Connection rating : 174 W  
 Voltage : 220-240 V  
 Frequency : 50; 60 Hz  
 Plug type : GB plug  
 Installation type : Island



4 242005 103997

## Serie | 6, Ceiling cooker hood, 90 cm, Stainless steel DRC97AQ50B

**The integrated ceiling hood: the powerful and effective solution for larger and open plan kitchens, perfectly installed directly into the ceiling.**

### Key performance features:

- Energy Efficiency Class: A (at a range of energy efficiency classes from A+++ to D)
- Extraction rate according to EN 61591 ø 15 cm:  
max. Normal use 458 m<sup>3</sup>/h  
Intensive 798 m<sup>3</sup>/h
- Noise max. Normal Level: Noise, max. speed in normal us: 56 dB dB\*

### Home Connect: Remote Monitoring and Control

- Home Connect: Remote Monitoring and Control for connected home appliances and operation via smartphone or tablet (only in countries where Home Connect service is available)
- The Home Connect functionality can be extended by integrating numerous applications from external cooperation partners (partnerships)
- Voice Control enabled via popular voice assistants (only in countries where this service is available)
- Interval function: available via Home Connect
- Silence function: available via Home Connect

### Special features

- Hob based hood control
- Electronic display
- Infrared remote control
- 3 power levels and 2 intensive settings
- 4 x 3W LED lights
- Colour Temperature: 3500 K
- Dimmer function
- Interval operation
- Automatic intensive revert (6mins)
- Automatic after running (Automatic after running (10 min))
- 2 removable metal grease filter cassettes
- Saturation indicator for metal and charcoal filter
- easy to clean Inner frame
- Rim ventilation

### Design

- Installation: Ceiling
- Electronic control
- Efficient BLDC technology
- Rotatable motor: possible to position the air outlet on all four sides

### Performance/technical information

- Suitable for ducted or recirculating operation
- For recirculated extraction CleanAir recirculating kit (accessory) needed
- Extraction rate according to EN 61591 max. 798 m<sup>3</sup>/h
- Noise level according to EN 60704-3 and EN 60704-2-13 at max. normal use exhaust air: 56 dB(A) re 1 pW
- Noise level according to EN 60704-3 and EN 60704-2-13 exhaust air:  
Max. normal use: 56 dB(A) re 1 pW  
Intensive: 68 dB(A) re 1 pW
- Noise level according to EN 60704-3 and EN 60704-2-13 at maximum normal setting: extraction rate: 56 dB (A) re 1pW
- With the Clean Air Plus recirculation kit (available as optional accessory) your appliances reaches:  
Extraction rate in recirculation mode:  
Max. normal use: 422 m<sup>3</sup>/h  
Intensive: 565 m<sup>3</sup>/h  
Noise level in recirculation mode with Clean Air Plus odor filter :  
Max. normal use: 63 dB(A) re 1 pW  
Intensive: 69 dB(A) re 1 pW
- Power rating: 174 W
- Light Intensity: 659 lux
- Electrical cable length 1.3 m
- Diameter pipe ø 150 mm (ø 150 mm enclosed)
- Dimensions exhaust air (HxWxD): 300-300 x 900 x 500 mm
- Dimensions recirculating (HxWxD): 300-300 x 900 x 500 mm
- Blower Efficiency Class: A\*
- Lighting Efficiency Class: A\*
- Grease Filtering Efficiency Class: E\*
- Average Energy Consumption: 34 kWh/year\*

### Optional accessories

- Recirculating kit DIZ1JC2C6

\* In accordance with the EU-Regulation No 65/2014

**Serie | 6, Ceiling cooker hood, 90 cm,  
Stainless steel  
DRC97AQ50B**

The fan outlet can be turned  
in all four directions

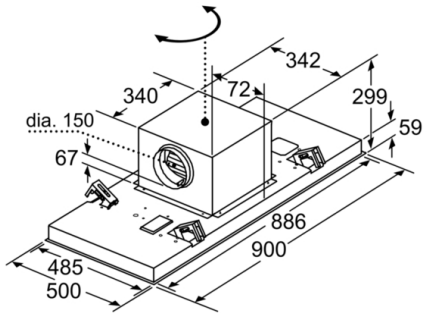

measurements in mm

measurements in mm  
Air extraction

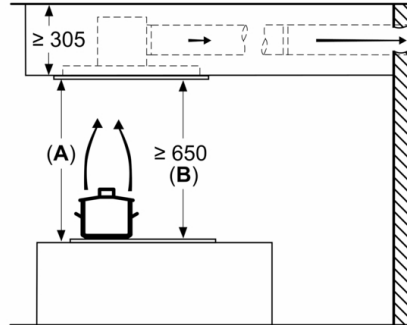

**A:** Optimum performance 700-1500  
**B:** From upper edge of pan support

measurements in mm  
Air recirculation

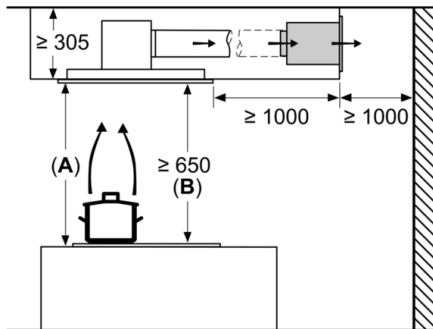

**A:** Optimum performance 700-1500  
**B:** From upper edge of pan support

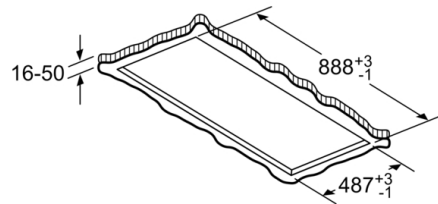

Never fit directly onto plasterboard or similar  
lightweight construction materials of the  
suspended ceiling. A suitable substructure  
is required that is securely fixed to the  
concrete ceiling.

measurements in mm

measurements in mm  
Air recirculation

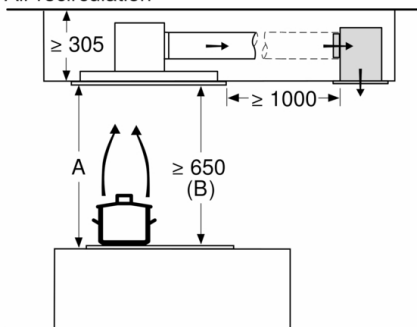

**A:** Optimum performance 700-1500  
**B:** From upper edge of pan support