

Serie | 8, Built-in freezer, 177.2 x 55.8 cm
GIN81HCE0G



The NoFrost freezer with electronic temperature control: set the target temperature precisely and easily.

- **VarioZone:** more flexibility due to variable-use glass shelves and drawers in the freezer compartment.
- **Automatic super freezing:** for freezing smaller food loads faster whilst protecting your frozen items from defrosting, thanks to the detection of temperature increase
- **NoFrost:** never defrost again, thanks to perfect protection from ice formation - that saves time and effort.
- **BigBox frozen food drawer:** for stacking storage containers or for large frozen food items.
- Temperature sensors continually monitor the temperature inside and outside the built-in fridge.

Technical Data

Energy Efficiency Class (Regulation (EU) 2017/1369):	E
Average annual energy consumption in kilowatt hour per year (kWh/a) (EU) 2017/1369:	235
Sum of volume of frozen compartments (EU 2017/1369):	212
Airborne acoustical noise emissions (EU 2017/1369):	35
Airborne acoustical noise emission class (EU 2017/1369):	B
Thermometer freeze section:	Digital
Light:	No
Product category:	Upright freezer
Construction type:	Built-in
Door panel options:	Not possible
Frost free system:	Fridge and freezer
Height of the product (mm):	1772
Width of the appliance:	558
Depth of the product:	545
Dimensions of the packed product (HxWxD) (mm):	1840 x 640 x 620
Net weight (kg):	65.583
Gross weight (kg):	70.8
Connection rating (W):	120
Current (A):	13
Frequency (Hz):	50
Approval certificates:	CE, VDE
Length of electrical supply cord (cm):	230
Door hinge:	Left reversible
Storage Period in Event of Power Failure (h):	9
Warning signal / malfunction:	visual and audible
Lockable door:	No
Number of drawers/baskets (Stck):	5
Number of freezing flaps (Stck):	2
EAN code:	4242005225699
Brand:	Bosch
Product name / Commercial code:	GIN81HCE0G
Product category:	Upright freezer



Serie | 8, Built-in freezer, 177.2 x 55.8 cm GIN81HCE0G

The NoFrost freezer with electronic temperature control: set the target temperature precisely and easily.

- GIN81HCE0G
- No Frost, Built-in tall freezer
- Fixed hinge

Design features

- No Frost, never have to defrost ever again
- Home Connect: Remote Monitoring and Control
- Fixed hinge
- LED Electronic control
- 1 compressor/1 cooling circuit
- SuperFreeze function with automatic deactivation
- FreshSense - Constant temperature control by intelligent sensor technology
- Freezer malfunction warning signal: optical, acoustical

Freezer Section

- 2 freezer flaps with glass shelves
- 5 transparent freezer drawers, 2 BigBox

Technical Information

- Door left hinged, door reversible
- Connection value 120 W
- 220 - 240 V

Dimension and installation

- Niche Dimensions: 177.5 cm H x 56 cm W x 55 cm D
- Dimensions: 177.2 cm H x 55.8 cm W x 54.5 cm D

Accessories

- ice cube tray

Country Specific Options

- Based on the results of the standard 24-hour test. Actual consumption depends on usage/position of the appliance.

Additional features

Performance and Consumption

- EU19_EEK_D: E
- Total Volume : 212 l
- Freezing capacity 24h : 14 kg
- Annual Energy Consumption: 235 kWh/a
- Climate Class: SN-T
- Noise Level : 35 dB
- Temperature rise time : EU19_Temperature rise time_D: 9 H

Serie | 8, Built-in freezer, 177.2 x 55.8 cm GIN81HCE0G

Maximal permissible weight of the unit fronts

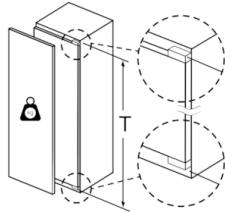

Fitted kitchen unit doors that exceed the permissible weight may cause damage and result in functional impairment of the hinges.

T: Includes height of appliance door	undamped hinge, Door in kg:	damped hinge, Door in kg:
Hinges in mm: 1500-1750	22	22

measurements in mm

Recommended gap dimensions for flat hinges

F	R	X
16-19	0-3	2.5
20	0-1	3
	2-3	2.5
21	0-1	3
	2-3	2.5
22	0	4
	1	3.5
	2-3	3

The gap dimensions recommended in the table must be adhered to in order to ensure that appliance doors do not collide with anything when they are opened, and to avoid causing damage to kitchen units.

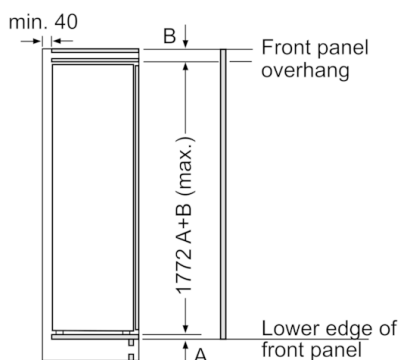
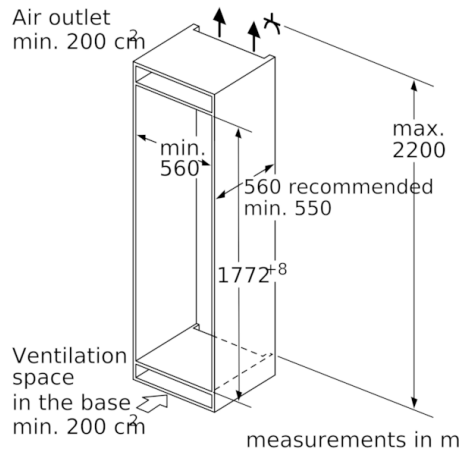
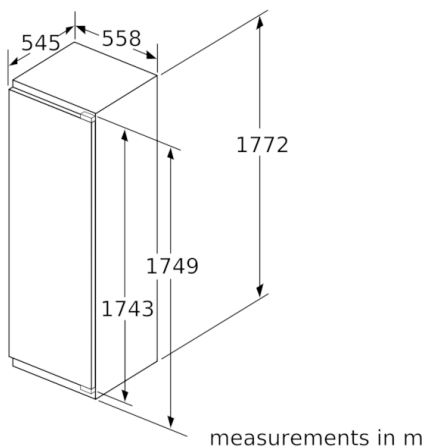

measurements in mm